

Panasonic
ideas for life

PT-D5500U/UL

DLP™-Based Projector

**Advanced Design Teams with
Flexible, Reliable Operation**





A Synergy of Technologies Achieves Superior Quality, High Reliability and Low Operating Costs

The PT-D5500U/UL brings together three advancement — DLP™ technology, dual lamp system, and liquid cooling — to deliver bright, high-quality images and quiet, reliable operation.

Panasonic's acclaimed dual lamp system generates 5,000-lumen brightness, so the vivid, high-resolution images made possible by DLP™ technology are easy to see in any installation environment.

In the Dual Lamp system, the lamp relay function in single lamp mode automatically switches the bulb when one of the lamps burns out, allowing continuous, non-stop operation. Panasonic's newly developed liquid-cooling system directly cools the DMD chip, giving the PT-D5500U/UL the reliability needed for 24/7 operation. The cooling system also reduces the number of cooling fans needed, so operating noise is greatly reduced. You'll find the PT-D5500U/UL quiet enough to use almost anywhere.

DMD chip

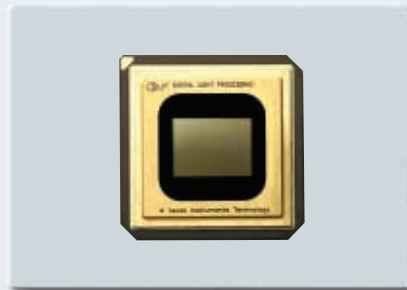

Liquid-Cooling System

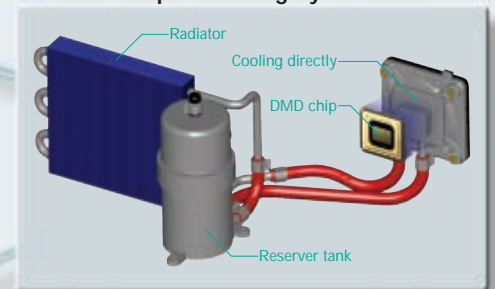

Dual Lamp System

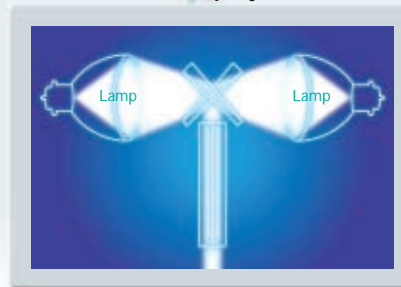

Ecology-Conscious Design

Panasonic works from every angle to minimize environmental impact in the product design, production and delivery processes, and in the performance of the product during its life cycle. The PT-D5500U/UL reflects the following ecological considerations.

- Lead-free solder is used to mount components to the printed circuit boards.
- The non-coated cabinet enables easy recycling.
- Lamp power switching further reduces power consumption.
- Auto Power Save activates standby mode when no signal is input.
- The packing case and operating manual are made from recycled paper.



High Image Quality

Ultra Bright 5,000 Lumens

A single-chip DLP™ design, liquid-cooling system and dual-lamp optical system team up to achieve a brightness of 5,000 lumens. This enables bright, large-screen projection even in well-lit condition.

Number of Lamp	Lamp mode	Brightness	
		Normal Lamp	Long Life Lamp
Dual	High	5,000 lm	2,500 lm
	Low	4,000 lm	
Single	High	2,500 lm	1,250 lm
	Low	2,000 lm	

High 1,600:1 Contrast Ratio

This high-contrast combines with an outstanding brightness for crisp, high-resolution images in virtually any viewing environment. Contrast can be switched between High and Normal as conditions require.

Contrast Mode	Contrast	Brightness	
		Normal Lamp	Long Life Lamp
High	1,600:1	2,500 lm	1,250 lm
Low	800:1	5,000 lm	2,500 lm

Under Dual lamp condition

High Uniformity of Brightness and Color

The PT-D5500U/UL's outstanding brightness and contrast ratio assures high uniformity of brightness and color, resulting in vivid and natural image.

Progressive Cinema Scan (3/2 Pulldown)

This interlace/progressive conversion technology automatically detects when the input signal is derived from filmed material and selects the optimum progressive processing method to assure faithful reproduction of the original image.



Dynamic Sharpness Control

The Dynamic Sharpness Control circuit adjusts the video signal waveforms based on the difference in brightness of adjacent pixels for a sharp, clear picture that is relatively unaffected by signal noise.

High Reliability and Easy Maintenance

Liquid Cooling System

Panasonic's newly developed liquid-cooling system directly cools the DMD chip, which extends the PT-D5500U/UL's performance and attains a high level of reliability.

Dustproof Design with Sealed Optical Block

The effect of dust has been minimized by completely sealing the optical block. The dust-free design helps ensure that this DLP™ projector will continue to deliver crisp, sharp, high-resolution images over an extended service life.

Dual Lamp System and Lamp Relay Function

The use of two lamp systems increases brightness and eliminates the need to interrupt a presentation if a lamp burns out (in dual lamp operation mode). In single lamp operation mode, the lamp relay function greatly extends continuous operating time.

Optional Long-Life Lamp

A long-life lamp that stretches lamp life to 4,000 hours is available as an option. In single lamp operation mode, the lamp relay function allows non-stop operation 24 hours a day for up to 47 weeks without replacing the lamps. The use of UHM lamps dramatically cuts operating costs.

Easy Replacement of Dust Filter and Lamp

Dust filter is replaced from the side and lamps are replaced from the back panel. Both of them are replaced very easily even if PT-D5500U/UL is installed.



Flexible System Applications

Lens-Centered Design

A lens-centered, symmetrical design provides flexible system layout, eliminating the need for any special considerations when planning the installation site.

Horizontal/Vertical Lens Shift

A wide adjustment range of the horizontal/vertical lens shift assures distortion free images and adds convenience and versatility. (Horizontal : manual, Vertical : powered)

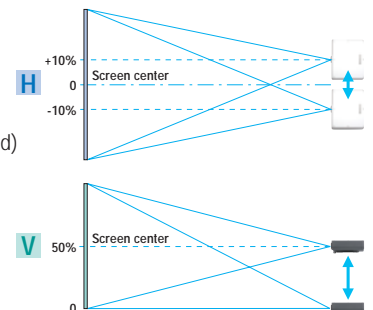

Optional Lenses For Various Venues

Five optional lenses with different throw distances are available in addition to the supplied lens. These powered zoom/focus lenses enable the projectors to perform superbly in an array of projection environments.

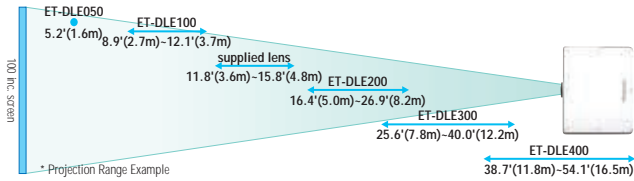

Easy Lens Replacement

The PT-D5500U/UL uses the bayonet system, so lenses attach and detach with one-touch ease.



Multiple Terminals Including DVI-D

The PT-D5500U/UL has an array of terminals—two RGB inputs including a 5-BNC connector, serial in/out one S-video inputs, two remote in, one remote out, DVI-D and control capability—to support a broad range of projection needs.



Control Panel And Wireless Remote Control

The rear control panel allows for easy operation when the PT-D5500U/UL is set on a desk or floor. A Multi-function wireless remote control with mouse control also comes supplied with each projector.



* Requires the optional ET-RMRC2 wireless mouse receiver

Quiet Operation, 29dB*

The unique Panasonic silent design ensures that the audience is not disturbed by projector noise.

* with lamp mode:low

Networking

Wired LAN System

The PT-D5500U/UL comes standard-equipped with a LAN connector for 10Base-T/100Base-TX connection. Simply hook it up to your existing LAN network for easy remote control and/or monitoring. System administrators will appreciate this feature when using the PT-D5500U/UL as a fixed-installation projector.

Web Browser Control/Monitoring

Anybody can operate the PT-D5500U/UL by remote control or monitor its status over a LAN network, because it is all done using the computer's familiar Web browser.

E-Mail Message Alert

The PT-D5500U/UL automatically sends an E-mail message to notify the operator when an error has occurred, or a lamp needs to be replaced.

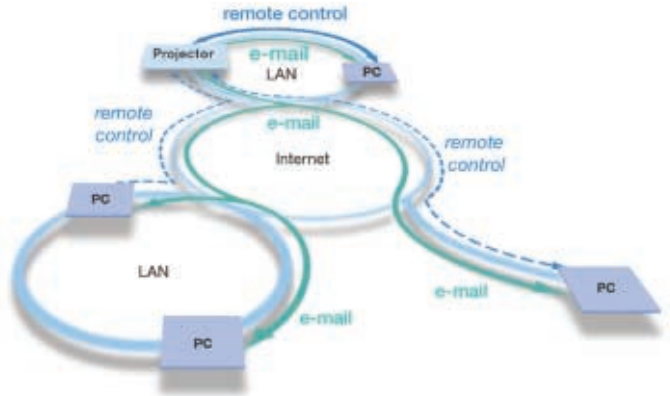

Other Valuable Features

Direct Power Off

Built-in capacitor provides power to cool the internal parts. This means that you can switch off the room's main power as soon as the presentation ends. It doesn't make you wait around and helps minimize lamp damage.

Anti-Theft Features With Chain Opening

Anti-theft features help protect the PT-D5500U/UL from unauthorized use, including a password protection function and an operation key lock function that disables the control buttons on the main unit. It also features a Kensington lock and an additional security chain opening.

Customizable Top Panel

The top panel can be customized by adding your company's logo or changing the color if desired. Please ask your dealer for details.



Flexible Angle Setting

The PT-5500U/UL can be rotated vertically. This means you can install it at any up-and-down angle you wish to accommodate different installation conditions.



Others

- 6 colors-matching function (red, green, blue, cyan, magenta, yellow)
- ID assignment for up to 65 units
- Coordinated group control for up to 26 groups (A-Z)
- Digital vertical keystone correction
- 3x digital zoom
- Built-in test pattern
- Selectable 9-language on-screen menu (English, German, French, Spanish, Italian, Russian, Japanese, Chinese, Korean)

The PT-D5500UL delivers the same performance as the PT-D5500U, but comes without lens. Combine it with an optional lens to get the exact performance you need according to usage and operating conditions.



Superior Brightness, Image Quality and Reliability

DLP™ technology combines with Panasonic's dual lamp system and new liquid-cooling system in a projector that stands out for image quality, brightness and reliability.

The PT-D5500U/UL packs a host of leading technologies into a compact body with a lens-centered symmetrical design.

Thanks to DLP™ technology, the PT-D5500U/UL projects images with a sharpness and resolution suitable for the highest-level applications.

The dual lamp system delivers 5,000-lumen brightness, ensuring that the images are bright and easy to see in any environment.

And thanks to Panasonic's newly developed liquid-cooling system, the PT-D5500U/UL can provide reliable, whisper-quiet operation 24 hours a day, 7 days a week for extended periods.

The lens, lamp, and dust filter are easy to replace, making maintenance easy.

You can connect the PT-D5500U/UL to a LAN and control or monitor it via a Web browser.

A wide range of lenses are available as options to meet all your projecting needs.

With its high reliability, low operating costs and long-term durability, the PT-D5500U/UL is a high-cost-to-performance projector that brings DLP™ technology into reach of even limited budgets.

Conference rooms



Classrooms



Churches



Control rooms



The high-performance PT-D5500U/UL is ideal in applications from conference rooms, classrooms and church halls to control rooms and public facilities that operate on a non-stop 24/7 basis.

Its sleek, compact styling makes this projector a good match with virtually any decor.

And the PT-D5500U/UL can be mounted at any angle — with the lens pointing upward, downward, or anywhere in between — for easy installation.

With all this plus an array of optional lenses, the versatile PT-D5500U/UL is a solution for any application calling for high-quality projection.



Specifications

System	DLP™ system
Device	0.7" (diagonal) DMD™(x 1), 4:3
Pixels	786,432 (1,024 x 768) x 1
Lamp	300 W UHM™ lamp x 2 (BrightOptic™ Dual Lamp System)
Brightness (normal lamp)	5,000 lumens (dual lamp)
Brightness (long life lamp)	2,500 lumens (dual lamp)
Contrast ratio	1,600:1 (full white/full black, with contrast mode:high)
Resolution	
RGB	1,024 x 768 pixels
Video	560 TV lines
Lens	
PT-D5500U	Powered zoom/focus lens (1:1.8-1:2.5) F 1.7-2.0, f 25.6-33.8 mm
PT-D5500UL	Optional
Screen size	50 - 600" diagonal
Lens shift	Vertical, horizontal
RGB input scanning frequency	fH 15-91 kHz, fV 50-85 Hz Dot clock 24-108 MHz
Component signal	480i, 480p, 576i, 576p, 720/60p, 1035/60i, 1080/60i, 1080/50i
Video signal	NTSC, PAL, SECAM, M-NTSC, PAL60, PAL-M, PAL-N

Terminals	BNC
VIDEO IN	Mini DIN 4-pin
S-VIDEO IN	BNC x 5
RGB1/Y/PbPr IN	D-sub HD 15-pin
RGB2 IN	24 pin
DVI-D IN	D-sub 9-pin female
RS-232C IN	D-sub 9-pin male
RS-232C OUT	M3 jack
REMOTE 1 IN	M3 jack
REMOTE 1 OUT	D-sub 9-pin female (parallel)
REMOTE 2 IN	RJ-45(10 Base-T/100 Base-TX)
LAN	±30° (with supplied lens)
Keystone correction range	Front/rear, ceiling/floor (menu selection)
Installation	8.2"(2.5m)
Power code length	120 V AC, 60Hz
Power supply	770 W (770 VA) (10 W during standby mode with fan stopped)
Power consumption	20-7/8" x 6-37/64" x 16-47/64" (530 x 167 x 425 mm)
Dimensions(W x H x D)	
Weight	
PT-D5500U	30.2 lbs (13.7 kg) with supplied lens
PT-D5500UL	28.4 lbs (12.9 kg) without lens
Operating temperature	32°-104°F (0°-40°C)
Operating humidity	10-80% (no condensation)
Supplied accessories	<ul style="list-style-type: none"> • Wireless remote control unit • Batteries for remote control • Remote control cable

Dimensions

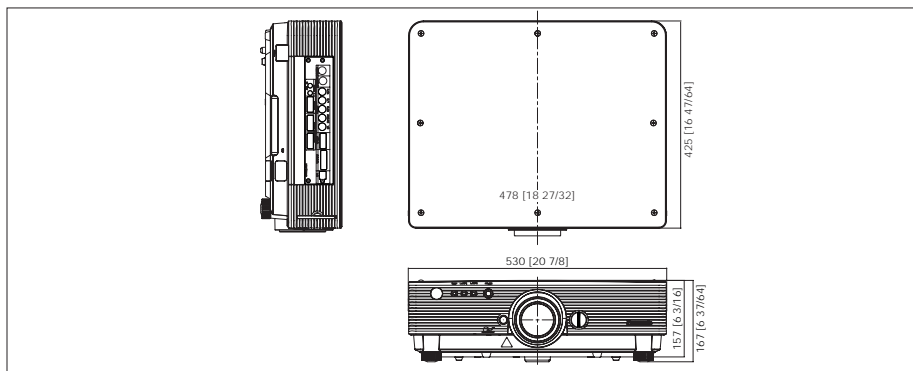

Projection distance

Screen size (4:3)	Throw distance											
	With ET-DLE050 0.8:1	With ET-DLE100 1.3-1.8:1 min.		With supplied lens 1.8-2.5:1 min.		With ET-DLE200 2.5-4.0:1 min.		With ET-DLE300 3.7-5.7:1 min.		With ET-DLE400 5.7-8.0:1 min.		
50"(4.2') 1.3 m	2.7' 0.8 m	4.4' 1.3 m	5.1' 1.8 m	5.9' 1.8 m	7.9' 2.4 m	8.0' 2.5 m	13.3' 4.1 m	12.7' 3.8 m	19.9' 6.0 m	19.5' 5.9 m	27.3' 8.3 m	
80"(6.7') 2.0 m	4.2' 1.3 m	7.1' 2.2 m	9.7' 2.9 m	9.5' 2.9 m	12.5' 3.8 m	13.0' 4.0 m	21.4' 6.5 m	20.4' 6.2 m	31.1' 9.7 m	31.0' 9.5 m	43.5' 13.2 m	
100"(8.3') 2.5 m	5.3' 1.6 m	8.1' 2.7 m	12.0' 3.7 m	11.8' 3.6 m	15.8' 4.8 m	16.4' 5.0 m	26.9' 8.2 m	25.7' 7.8 m	39.1' 12.2 m	38.8' 11.8 m	54.2' 16.5 m	
150"(12.5') 3.8 m	8.0' 2.5 m	13.5' 4.1 m	18.2' 5.5 m	18.0' 5.5 m	24.0' 7.3 m	24.7' 7.5 m	40.3' 12.3 m	38.8' 11.8 m	60.2' 18.4 m	57.1' 17.7 m	81.2' 24.8 m	
200"(16.7') 5.1 m	10.9' 3.3 m	17.1' 5.5 m	24.3' 7.4 m	24.0' 7.3 m	31.8' 9.7 m	32.1' 10.0 m	53.1' 16.4 m	51.8' 15.8 m	80.4' 24.5 m	77.1' 23.5 m	108.2' 33.0 m	
300"(25.0') 7.6 m	-	27.0' 8.3 m	36.5' 11.1 m	36.4' 11.1 m	47.9' 14.6 m	49.4' 15.1 m	80.1' 24.7 m	77.9' 23.7 m	120.1' 36.8 m	115.8' 35.3 m	162.2' 49.4 m	
400"(33.3') 1.3 m	-	36.1' 11.0 m	48.8' 14.8 m	48.6' 14.8 m	64.0' 19.5 m	65.1' 20.1 m	107.1' 32.9 m	103.1' 31.7 m	161.3' 49.2 m	154.3' 47.0 m	216.2' 65.9 m	
500"(41.7') 12.7 m	-	45.2' 13.8 m	60.1' 18.6 m	60.7' 18.5 m	80.1' 24.4 m	82.6' 25.2 m	134.1' 41.1 m	129.1' 39.6 m	201.8' 61.5 m	193.0' 58.9 m	270.3' 82.4 m	
600"(50.0') 15.2 m	-	54.3' 16.6 m	73.1' 22.3 m	72.8' 22.2 m	95.8' 29.2 m	99.0' 30.2 m	162.0' 49.4 m	156.0' 47.6 m	242.1' 73.8 m	231.1' 70.7 m	324.4' 98.9 m	

Optional accessories



NOTES ON USE

- The projector uses a high-voltage mercury lamp that contains high internal pressure. This lamp may break, emitting a large sound, or fail to illuminate, due to impact or extended use. The length of time that it takes for the lamp to break or fail to illuminate varies greatly depending on individual lamp characteristics and usage conditions.
- The brightness of the lamp will gradually decrease with use.
- The replacement cycle of the lamp will be shortened if the power is frequently turned on and off or the projector is subjected to daily continuous use for 10 or more hours.

Panasonic®

Panasonic Broadcast & Television Systems Company
Presentation Systems Group
1 888 843 9788
www.panasonic.com/projectors

Headquarters
1 Panasonic Way, 4E-7
Secaucus, NJ 07094
201 348 5300

Panasonic Canada Inc.
5770 Ambler Drive
Mississauga, Ontario
Canada L4W 2T3
905 624 5010

Please contact Panasonic or your dealer for a demonstration.



JQA-1617



Weights and dimensions shown are approximate. Specifications are subject to change without notice. This product may be subject to export regulations. UHM is trademark of Matsushita Electric Industrial Co., Ltd. VGA and XGA are trademarks of International Business Machines Corporation. All other trademarks are the property of their respective trademark owners. Projection images simulated.
PT-D5500U2-04Sep3K Printed in Japan.